



Aguirre

1,501 Square Feet

Community: Summer Sky North

LOGO	DESCRIPTION
	COAXIAL CABLE
	DATA
	ISP JUNCTION

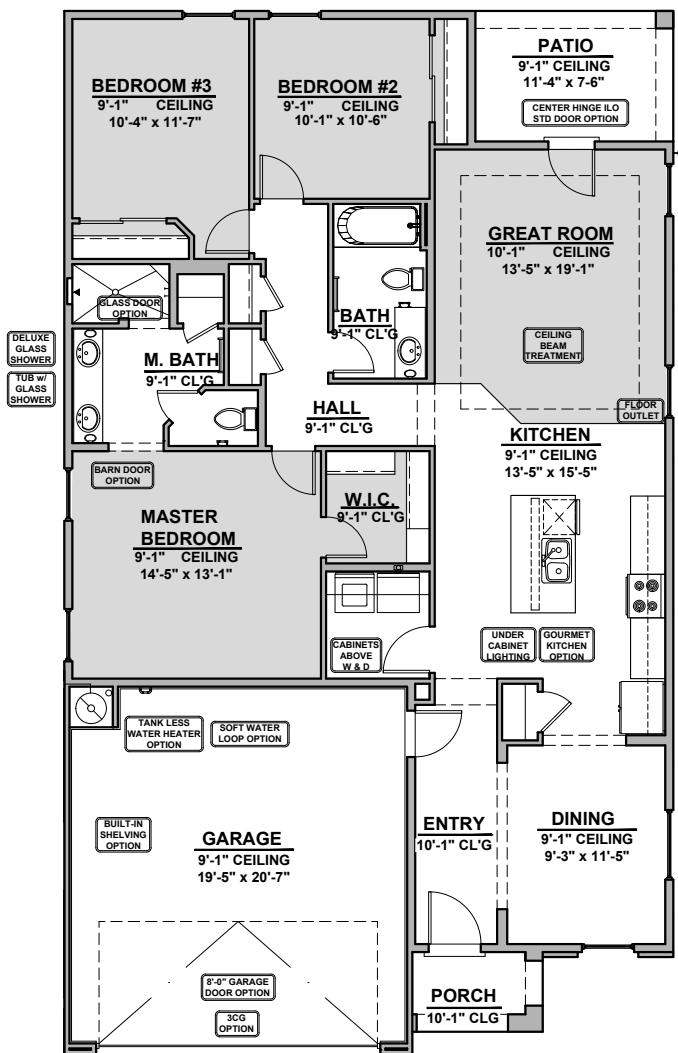

Ranch (R)

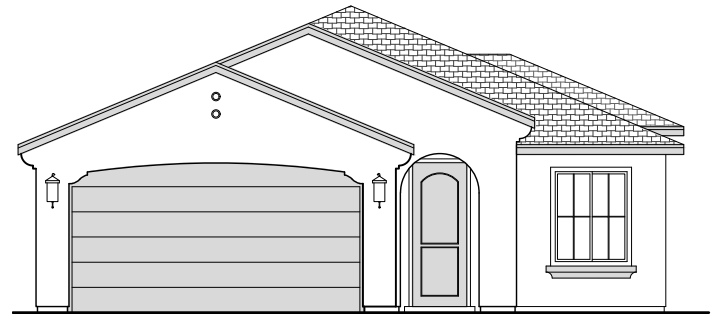

Southwest (S)

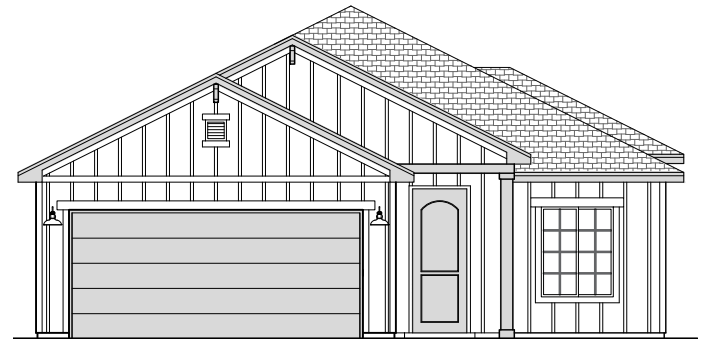

Modern Farmhouse (I)

Garage Orientation: Left Right

Home is complete and accepted as built. _____

Home construction is in process, buyer accepts all option locations. _____



Aguirre Options

1,501 Square Feet

Community: Summer Sky North

LOW VOLTAGE LEGEND	
LOGO	DESCRIPTION
	COAXIAL CABLE
	DATA
	ISP JUNCTION

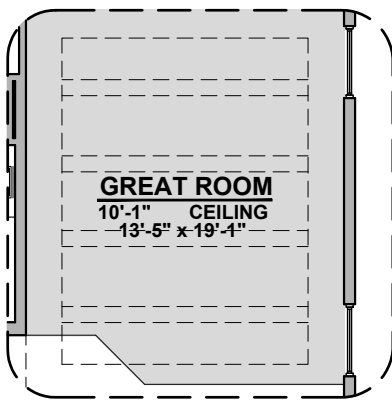

Ceiling Beam Treatment

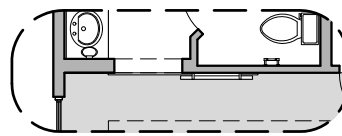

Barn Door

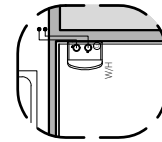

Tankless Water Heater

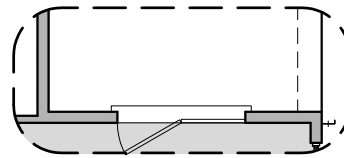

Center Hinge I/O Sliding Glass Door

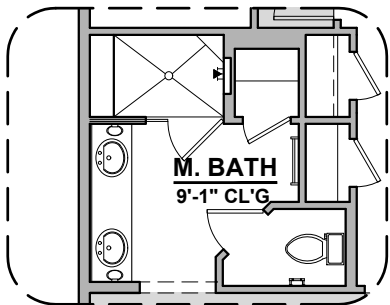

Deluxe Glass Shower

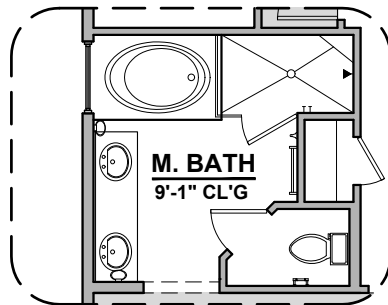

Tub w/ Glass Shower

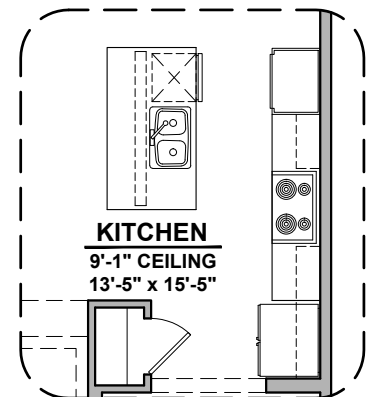

Gourmet Kitchen